

MU22P-F11Z△▲ER

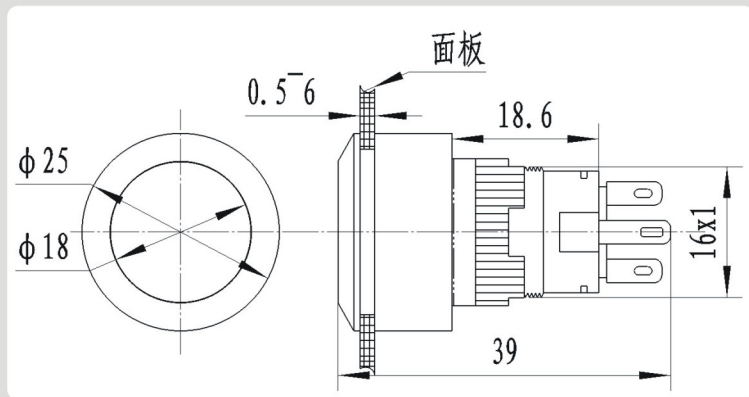

頭部釋義 Head Type	F/平面 T/斜面 C/凹凸 H/高頭 B/球面 E/環形燈 D/中心燈 F/Flat T/Inclined C/Concave H/High B/Ball E/Ring lamp D/Center lamp
外殼材料 Material	N/黃銅鍍鉻 A/鋅合金鍍鉻 S/不銹鋼P/塑料 N/Chromium plated brass A/Zinc alloy plated chromium S/Stainless steel P/PC
接線方式 Mode of connection	J/焊接式(1NO) 10/接線柱(1NO) 11/單刀(1NO,1NC) 22/雙刀(2NO,2NC) J/Pin terminal(1NO) 10/Wiring terminal(1NO) 11/Single pole(1NO,1NC) 22/Double knife(2NO,2NC)
額定電流 Rated Current	約5A About 5A
殼體顏色 Head Color	R G Y O B W
安裝尺寸 Diameter	Φ22mm
電壓等級 Voltage Rating	≤220V DC/AC
防護等級 IP Degree	IP67 IK10



產品規格	Sepecification	MU22P-F11Z△▲ER
保護等級	Degree of Protection	Ip67
觸點類型	Contact Type	1 NO 1NC / 2NO 2NC 可定制
最大電壓	Maximum Voltage	5V/250VAC
熱流	Thermal Current	5A
最小負載	Minimum Applicable Load	5V AC/DC, 1mA
觸點材料	Contact material	純銀合金Silver plated
端子形式	Terminal Style	.110" Solder/ Quick Connect
運行溫度	Operating Temperature	-25°C to +65°C
操作濕度	Operating Humidity	45 to 85% RH
接觸電阻	Contact Resistance	5mΩ maximum
絕緣電阻	Insulation Resistance	1000MΩ minimum (500V DC megger)
震蕩電阻	Vibration Resistance	10 to 55Hz, amplitude 1.2mm p-p
保護等級	Degree of Protection	>10g
電氣壽命	Electrical Life	200,000 operations minimum (at full rated load)
機械壽命	Mechanical Life	Maintained: 1000000 Momentary: 1000000 Selector/Keylock: 250000
耐壓	Dielectrical Life	Illumination Unit: 2,000V AC, 1 min. Between live part/ground
錫焊溫度	Soldering Temperature	20W/5 seconds or 260°C/3 seconds